

Feminist Machines: Biased Datasets & AI. Some Context and Creativity.

Peter van der Putten, Machine Learner & Creative Researcher, Universiteit Leiden



**Universiteit
Leiden**
The Netherlands

Leiden Institute of Advanced Computer Science
Media Technology MSc Program
Creative Intelligence Lab | [A]Social Creatures Lab

Discover the world at Leiden University



J.W. Waterhouse, 1903

Act I: AI in Historical and Societal Context



Universiteit
Leiden
The Netherlands

Discover the world at Leiden University

L' H O M M E
M A C H I N E.

*Est-ce là ce Raion de l'Essence suprême,
Que l'on nous peint si lumineux?
Est-ce là cet Esprit survivant à nous même?
Il nait avec nos sens, croit, s'affoiblit
comme eux.*

Helas! il périra de même.

V O L T A I R E.

À L E Y D E,
DE L'IMP. D'ELIE LUZAC, FILS.
M D C C X L V I I I.

1748



Julien Offroy
de la Mettrie, 1748





Imaginary Housekeeping Robot, 1940 (Cybernetic Zoo)

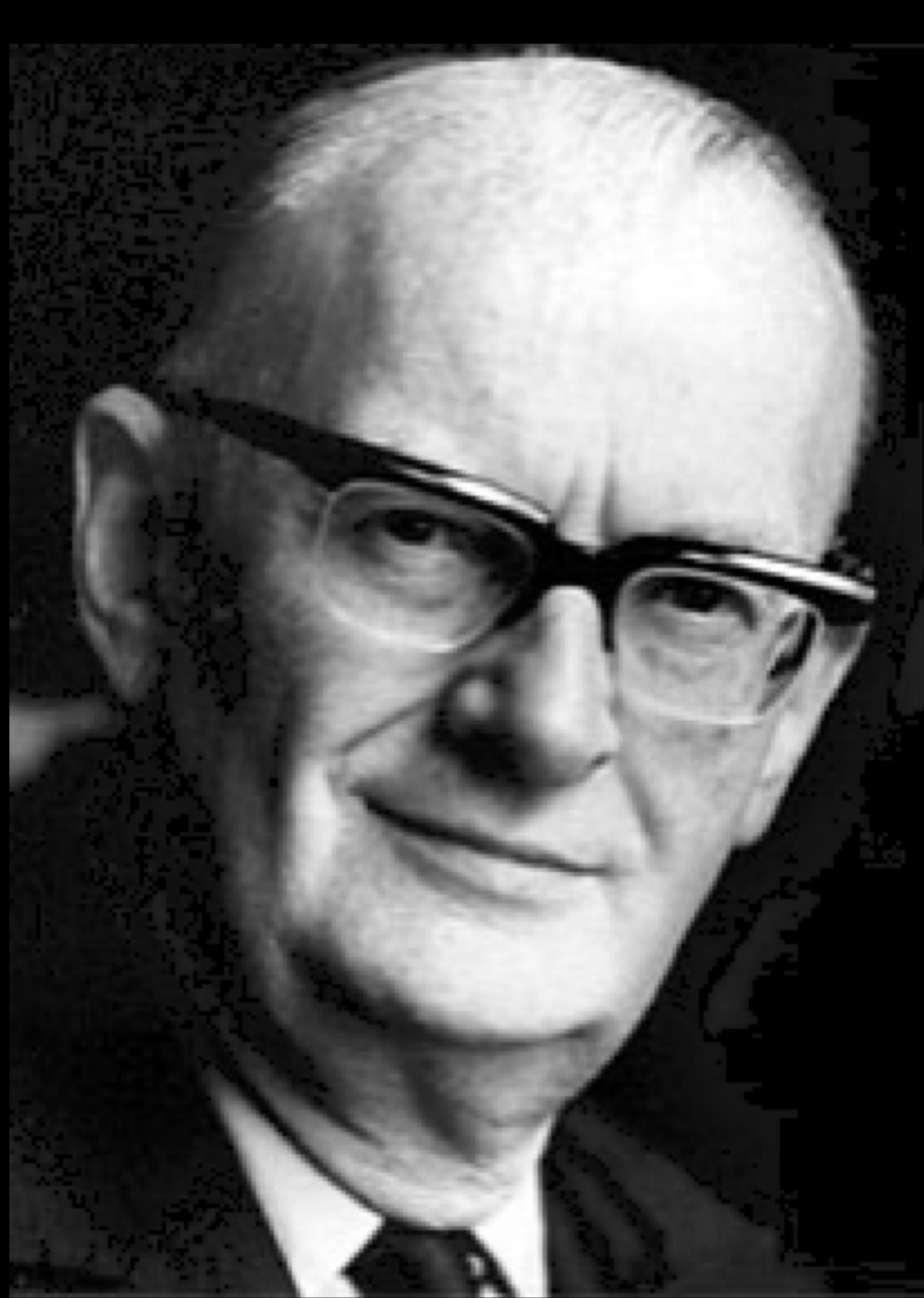

*“Any sufficiently
advanced technology
is indistinguishable
from magic”*

Arthur C. Clarke, science fiction writer

A. N. Turing



Instead of trying to produce a programme to simulate the adult mind, why not rather try to produce one which simulates the child's?

If this then would be subjected to an appropriate course of education one would obtain the adult brain.

Alan Turing, Computing Machinery and Intelligence, Mind 1950

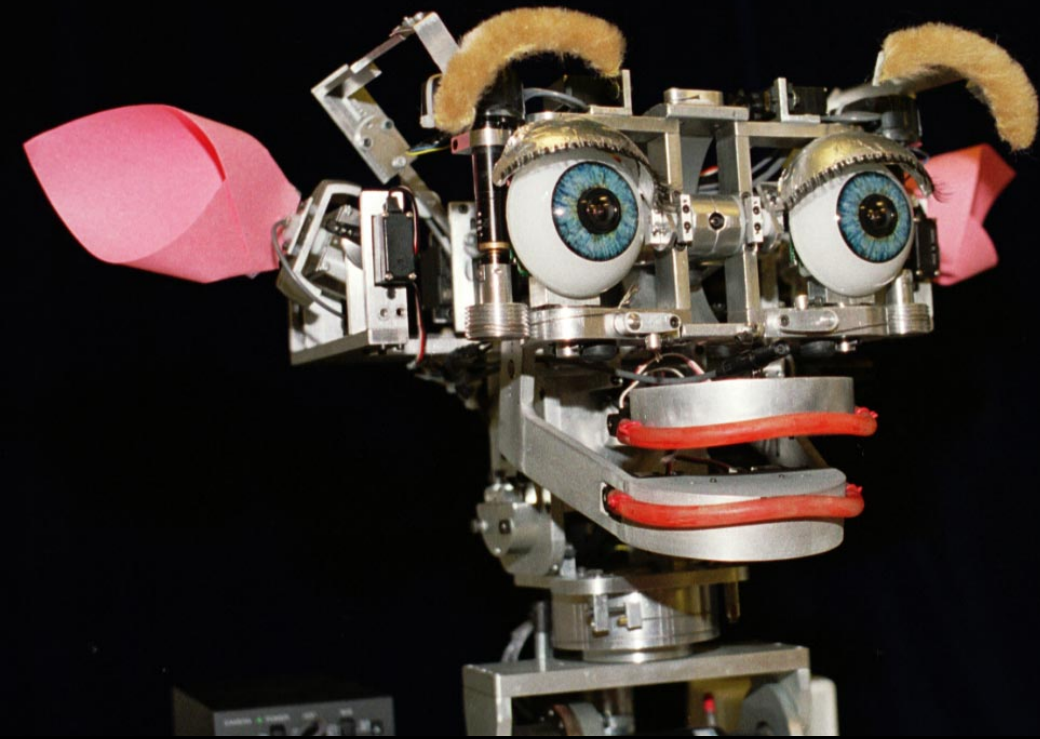

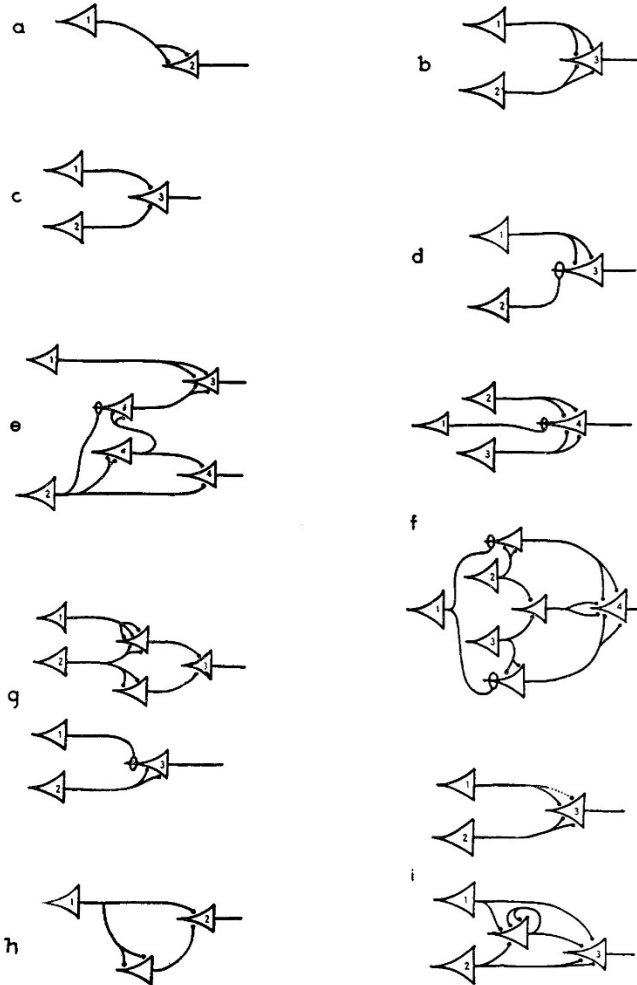

FIGURE 1

observations and of these to the facts is all too clear, for it is apparent that every idea and every sensation is realized by activity within that net, and by no such activity are the actual afferents fully determined.

There is no theory we may hold and no observation we can make that will retain so much as its old defective reference to the facts if the net be altered. Tinnitus, paraesthesias, hallucinations, delusions, confusions and disorientations intervene. Thus empiry confirms that if our nets are undefined, our facts are undefined, and to the "real" we can attribute not so much as one quality or "form." With determination of the net, the unknowable object of knowledge, the "thing in itself," ceases to be unknowable.

To psychology, however defined, specification of the net would contribute all that could be achieved in that field—even if the analysis were pushed to ultimate psychic units or "psychons," for a psychon can be no less than the activity of a single neuron. Since that activity is inherently propositional, all psychic events have an intentional, or "semiotic," character. The "all-or-none" law of these activities, and the conformity of their relations to those of the logic of propositions, insure that the relations of

← EXPRESSION FOR THE FIGURES

In the figure the neuron c_i is always marked with the numeral i upon the body of the cell, and the corresponding action is denoted by 'N' with i as subscript, as in the text.

- Figure 1a $N_2(t) \equiv \cdot N_1(t-1)$
- Figure 1b $N_3(t) \equiv \cdot N_1(t-1) \vee N_2(t-1)$
- Figure 1c $N_3(t) \equiv \cdot N_1(t-1) \cdot N_2(t-1)$
- Figure 1d $N_3(t) \equiv \cdot N_1(t-1) \cdot \sim N_2(t-1)$
- Figure 1e $N_3(t) \equiv \cdot N_1(t-1) \cdot \vee \cdot N_2(t-3) \cdot \sim N_2(t-2)$
 $N_4(t) \equiv \cdot N_2(t-2) \cdot N_2(t-1)$
- Figure 1f $N_4(t) \equiv \cdot \sim N_1(t-1) \cdot N_2(t-1) \vee N_3(t-1) \cdot \vee \cdot N_1(t-1) \cdot N_2(t-1) \cdot N_3(t-1)$
 $N_4(t) \equiv \cdot \sim N_1(t-2) \cdot N_2(t-2) \vee N_3(t-2) \cdot \vee \cdot N_1(t-2) \cdot N_2(t-2) \cdot N_3(t-2)$
- Figure 1g $N_3(t) \equiv \cdot N_2(t-2) \cdot \sim N_1(t-3)$
- Figure 1h $N_2(t) \equiv \cdot N_1(t-1) \cdot N_1(t-2)$
- Figure 1i $N_3(t) \equiv \cdot N_2(t-1) \cdot \vee \cdot N_1(t-1) \cdot (Ex)t-1 \cdot N_1(x) \cdot N_2(x)$

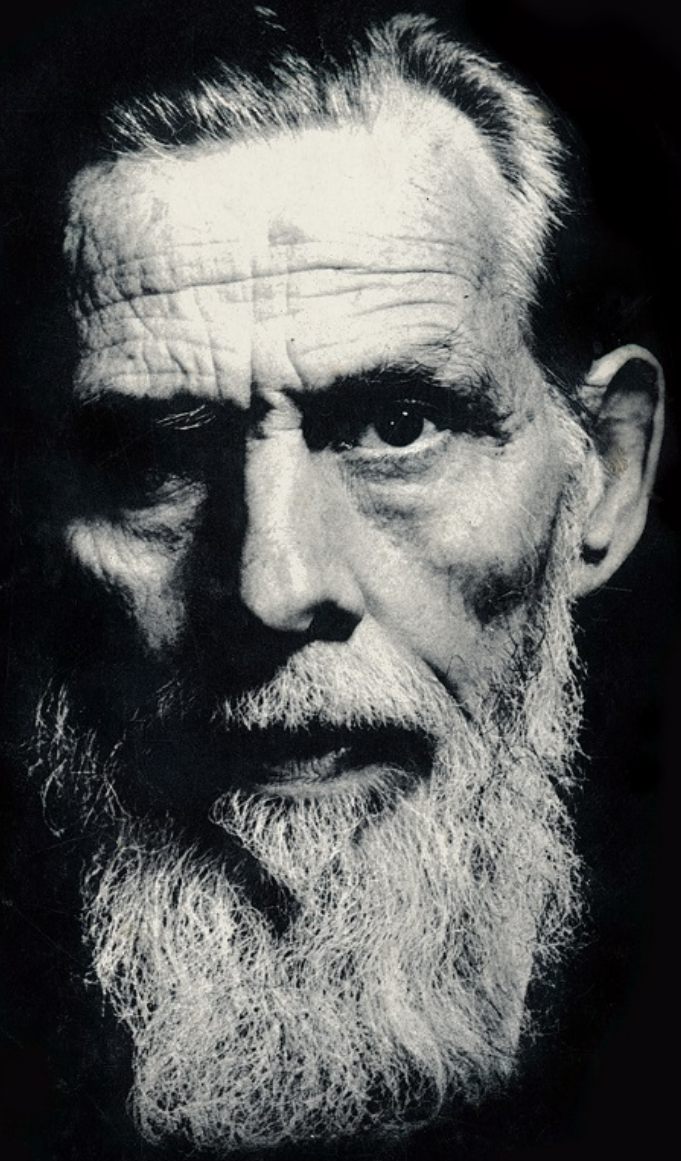

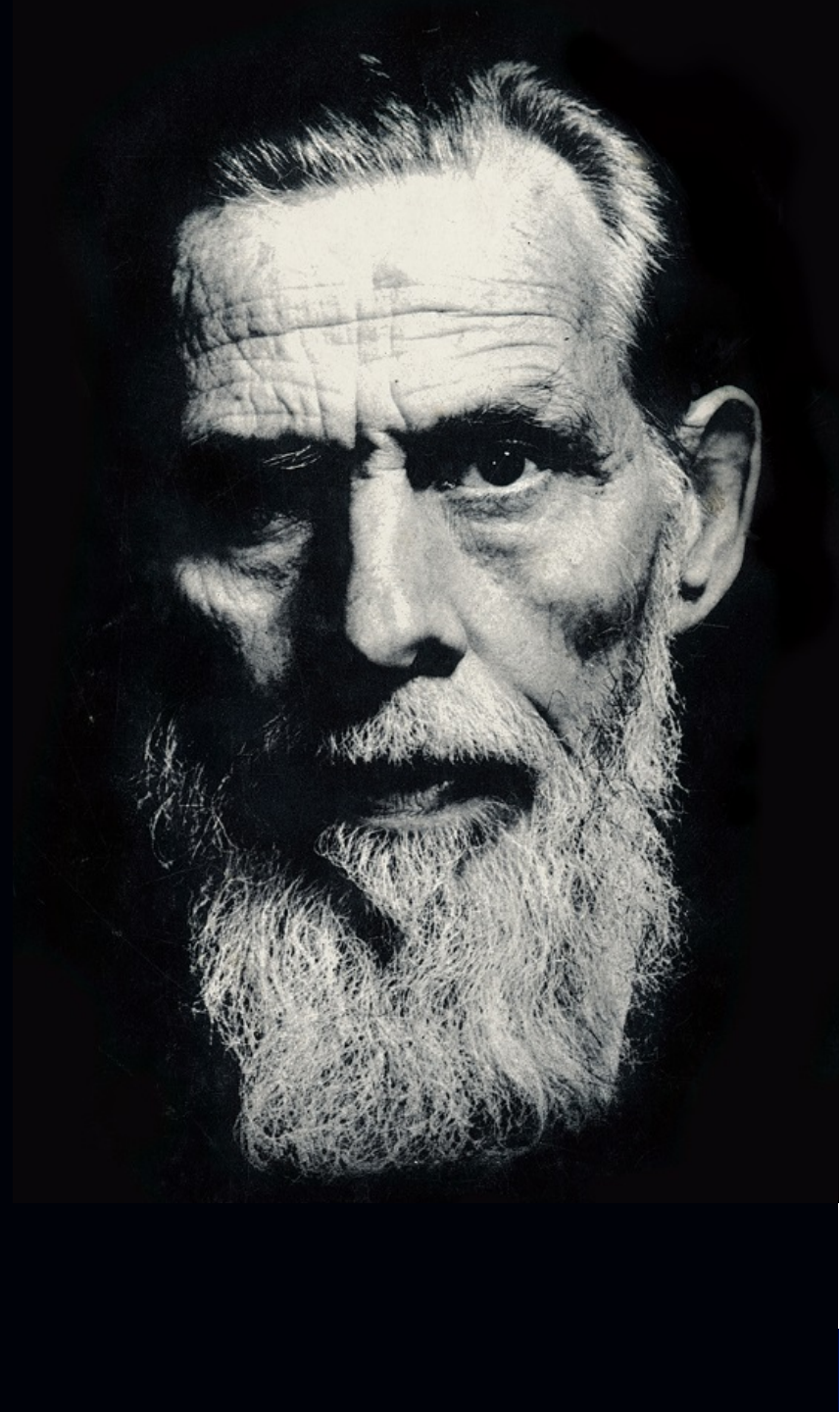
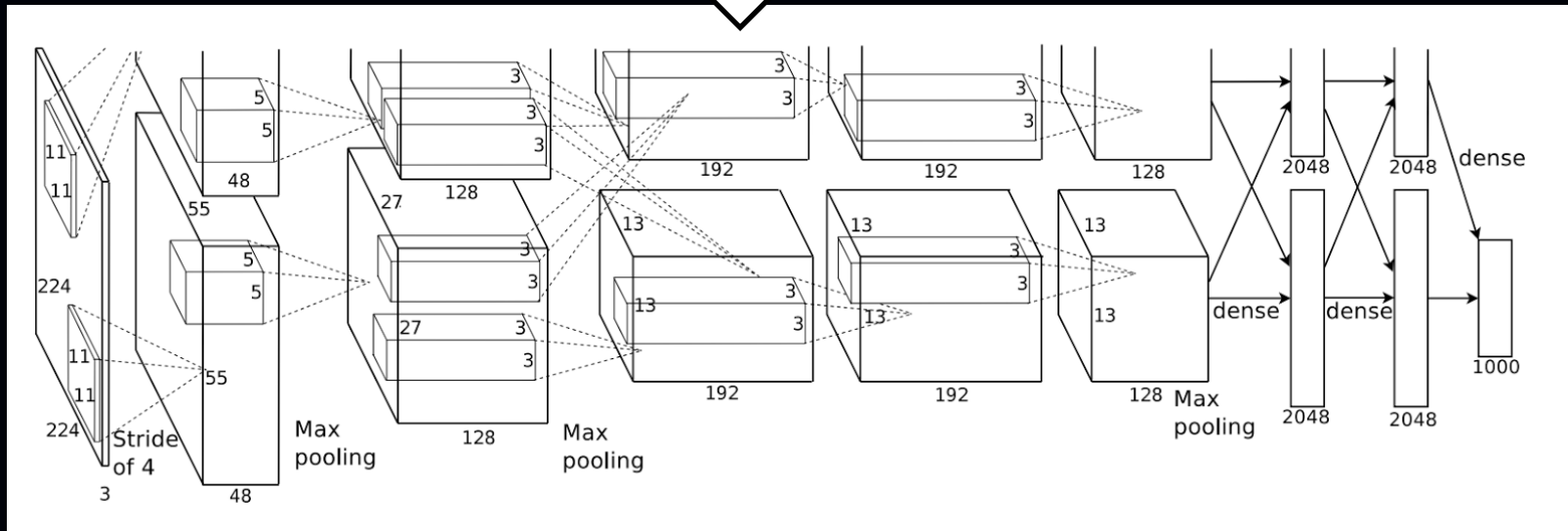
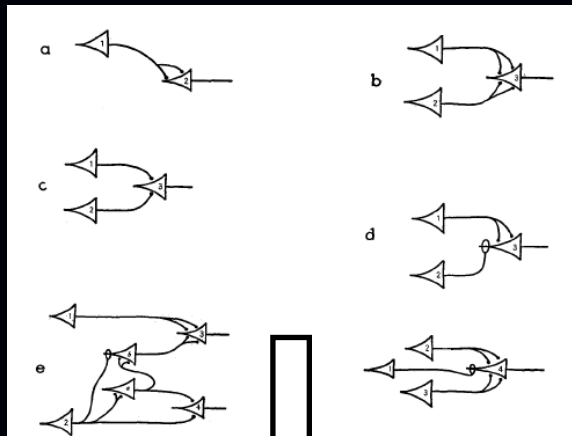

McCullough & Pitts, 1944

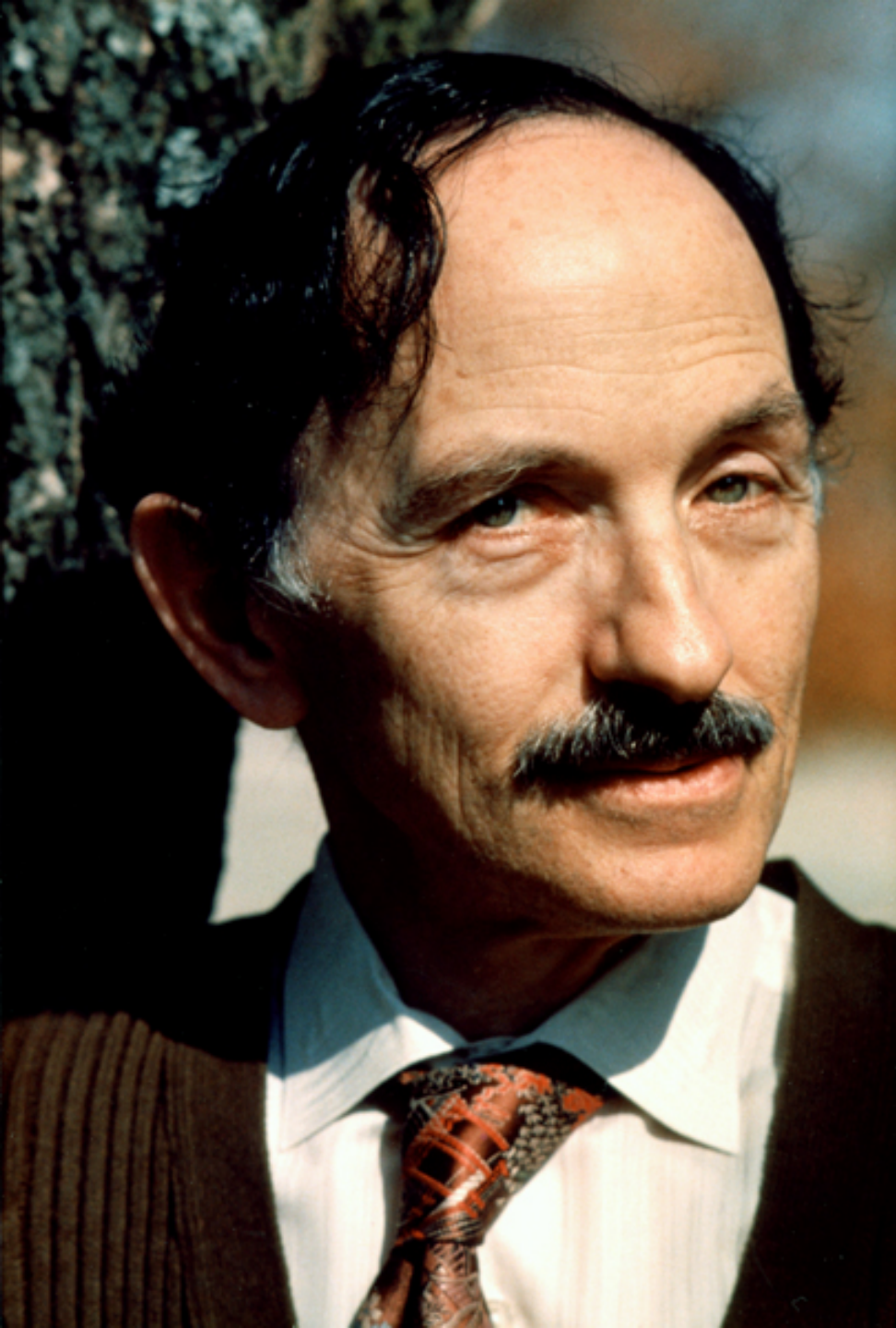

Let an **ultraintelligent machine** be defined as a machine that can far surpass all the intellectual activities of any man however clever.

Since the **design of machines is one of these intellectual activities**, an ultra-intelligent machine could design even better machines; there would then unquestionably be an ‘**intelligence explosion**’, and the intelligence of man would be left far behind.

Thus the first ultraintelligent machine is the **last invention** that man need ever make, provided that the machine is docile enough to tell us how to **keep it under control**



Photo: from movie *I Robot*, 2004



Facebook The Cambridge Analytica Files

Facebook's week of shame: the Cambridge Analytica fallout

Mark Zuckerberg kept his silence - then did little to assuage the anger in a week that laid bare the worst of Silicon Valley

Tim Adams

Sat 24 Mar 2018 21:11 GMT



505



\$60bn was wiped off Facebook's market capitalisation in wake of Zuckerberg's silence over data breach. Photograph: Justin Sullivan/Getty Images

Advertisement

Booking.com



€ 159

Zürich - Motel One Zürich

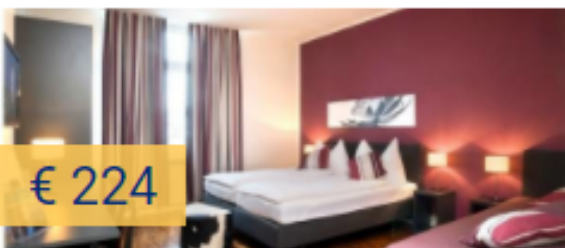

€ 224

Zürich - Hotel Hottingen



€ 230

People April 21, 2016 · Like Page

Prince wrote some surprising hits!



11 Popular Songs You Never Knew Prince Wrote
Madonna, The Bangles and Celine Dion have all had success with Prince-penned pieces
PEOPLE.MAG

41 Comments 834 Shares

Coca-Cola April 7 · Like Page

Coke... chips... guac... Coke... chips... guac... flavor...can't... handle... the... awesome...



1M Views

Jonathan Lee with Annie Diamond. February 25 · Like Page

M.A.L. Sigh



No safe forest left: 250 captive orphan chimps stuck in sanctuaries
Chimpanzees rescued from Cameroon's wildlife trade are safe in captivity, but NGOs can't find a safe forest in which to release them back to the wild.
NEWS.MONGABAY.COM



Game of Thrones February 7 · Like Page

You've seen the show and heard the soundtrack, now test your Game of Thrones music knowledge.



See How Well You Know the Music of GoT
You've seen the show and you've heard the soundtrack, now take a quiz on GoT music from Seasons 1-6.
MAKINGGAMEOFTHRONES.COM

National Park Service shared Mount Rainier National Park's Video. May 13 at 8:23pm · Like Page

Water, water, everywhere! Mount Rainier National Park is so much more than its namesake. There is an abundance of water within the park, often in the form of wa...
See More



67,192 Views

Coca-Cola April 7 · Like Page

Coke... chips... guac... Coke... chips... guac... flavor...can't... handle... the... awesome...



CHEVY MEMORIAL DAY SALES EVENT



NASA - National Aeronautics and Space Administration 30 mins · Like Page

It's no surprise that humans influence the surface of our planet, but our reach can go farther than that. Humans affect space, too. Learn more: <https://nasa.tumblr.com/.../16.../how-humans-change-space-itself>



"The Joy of Painting" with Bob Ross Yesterday at 9:39am · Like Page

The best cure for a case of the Mondays is a whole lot of Bob! Don't miss the 24 hour marathon going on right now at twitch.tv/bobross

24-Hour Marathon NOW! Go to www.twitch.tv/bobross



GoatsOfAnarchy May 14 at 12:19pm · Like Page

Prospect... don't let that sweet smile fool ya



Transavia Yesterday at 5:50am · Like Page

What a way to start the day! How was your morning?



AARP May 1 at 12:30pm · Like Page

Here's what you need to know to make the right medical alert system purchase.

How to Select the Best Medical Alert System
Learn how to evaluate your family's need, both now and in the future.
WWW.AARP.ORG



MGM Grand Las Vegas February 3 · Like Page

Life in the #Vegas lane. #HowManyDays until you check-in?
<http://mgm.gr/DHto6l>



7.7K 574 Comments 721 Shares 243K Views

Scotiabank Belize May 13 at 9:00am · Like Page

Get a team of experts in home-ownership to keep you on track towards your home ownership goals. #MortgageThatPays <http://bit.ly/2n30WFh>



Scotiabank Belize Finance Company

216 1 Comment 1 Share

Game of Thrones February 7 · Like Page

You've seen the show and heard the soundtrack, now test your Game of Thrones music knowledge.



See How Well You Know the Music of GoT
You've seen the show and you've heard the soundtrack, now take a quiz on GoT music from Seasons 1-6.
MAKINGGAMEOFTHRONES.COM

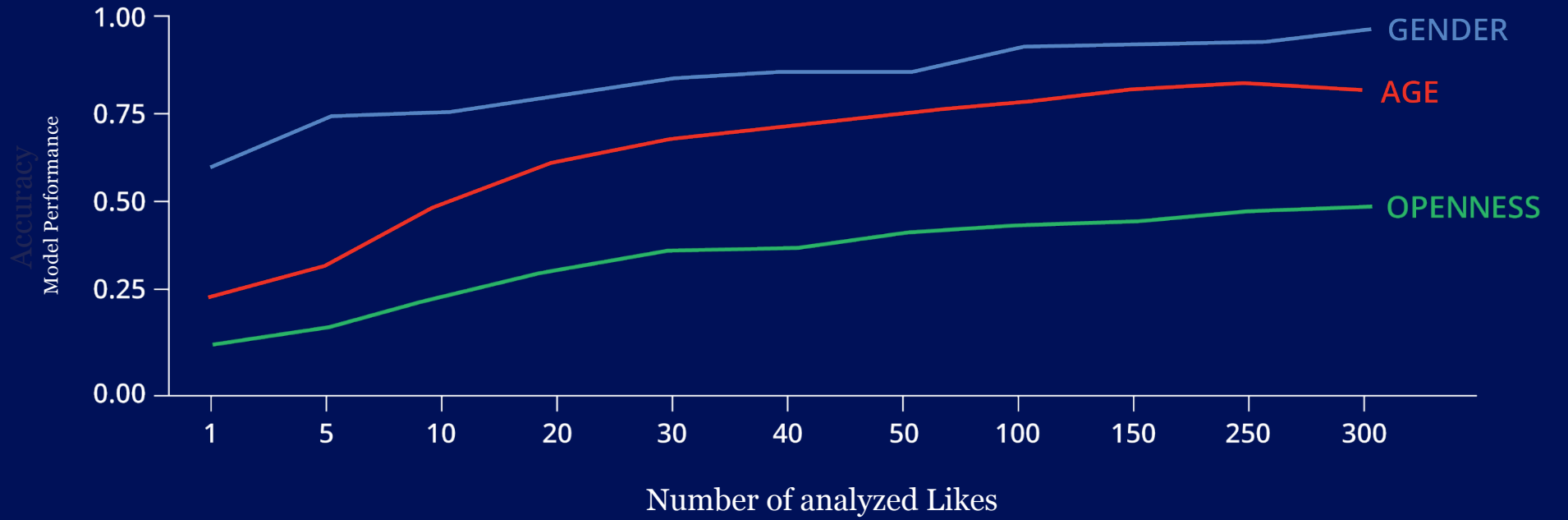

Source: *Private traits and attributes are predictable from digital records of human behavior*, Michal Kosinski, David Stillwell, and Thore Graepel

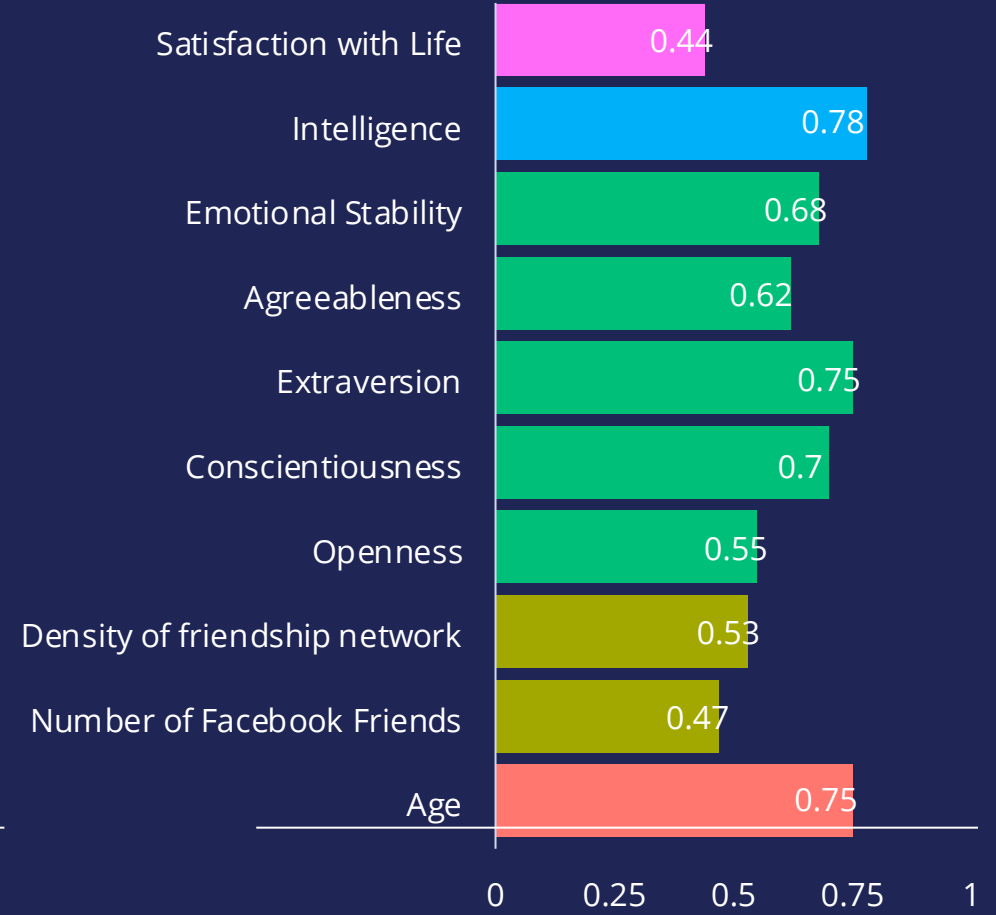
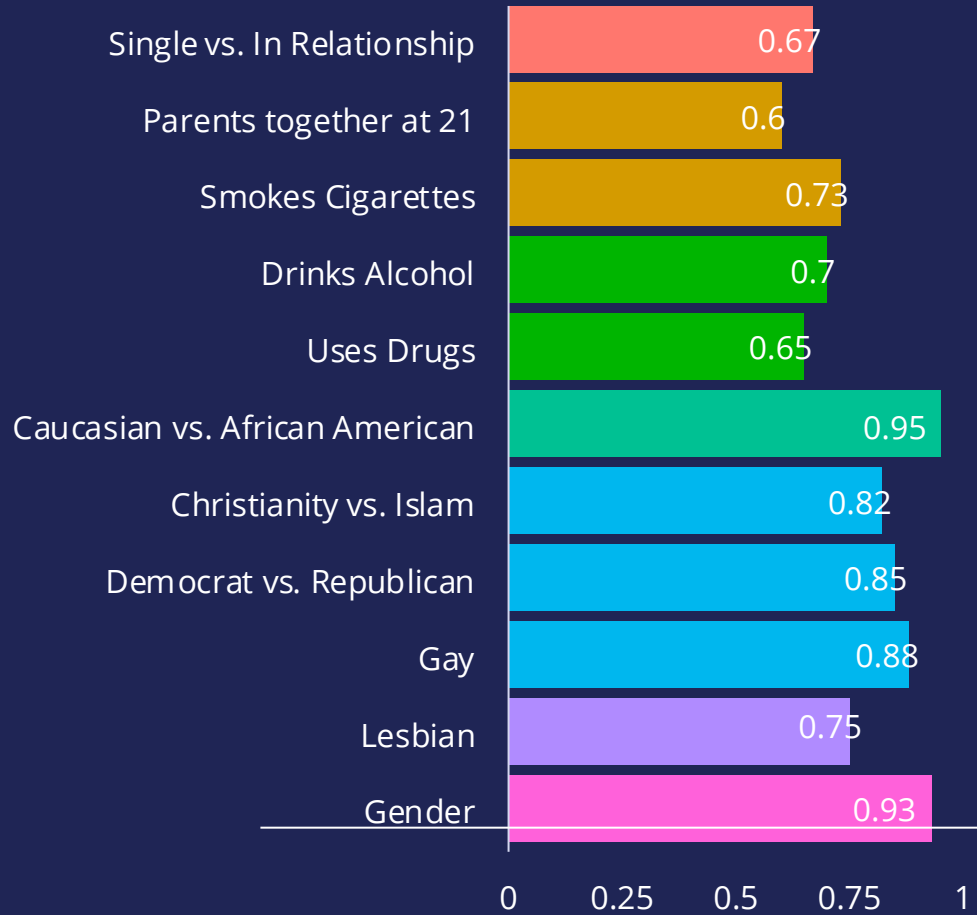

< Albums

chihuahua or muffin

Select



@teenybiscuit

< Back

labradoodle or fried chicken

Select



COMPUTING

How a Machine Learns Prejudice

Artificial intelligence picks up bias from human creators—not from hard, cold logic

By Jesse Emspak on December 29, 2016

NEWS

Home Video World UK Business Tech Science Stories Entertainment & Arts

Business Market Data Global Trade Companies Entrepreneurship Technology of Business

Apple's 'sexist' credit card investigated by US regulator

11 November



Home About Events Magazine Payments Race Really Cool Stuff ATMA Europe Episodes Event Videos Fintech TV Hong Kong

Money20/20 USA 2019 RBR ATM & Cyber Security SIBOS 2019 The Fintech Fix Thought Leadership

FinTech

RegTech

PayTech

InsurTech

LendTech

TradeTech

News

Apple card biased algorithms – expert explains how to reduce bias in AI

Posted on Nov 11, 2019

It has been reported that Apple's credit card offered different credit limits for men and women. In fact, even Apple's co-founder Steve Wozniak has expressed concerns that the algorithms used to set limits might be inherently biased against women.

Commenting on the news, and explaining how financial organisations can make sure that bias in artificial intelligence is kept to a minimum, Peter van der Putten, assistant professor at Leiden University and global director at Pegasystems, explains why these claims were especially painful for Apple as it brands Apple Card as a product that represents "All the things that Apple stands for". Like simplicity, transparency and privacy.

A US financial credit card

Disco

Apple Card: How To Eliminate Sexism From Banking Algorithms

A number of tweets earlier this week from some disgruntled customers revealed accusations that the Apple Card credit card managed by Goldman Sachs offered different credit limits for men and women with similar circumstances and backgrounds.



Below Peter van der Putten, assistant professor at Leiden University and global director AI at Pegasystems, explains why these claims were especially painful for Apple as it brands Apple Card as a product that represents "All the things that Apple stands for". Like simplicity, transparency and privacy.

It all started with a recent tweet by David Heinemeier Hansson, claiming his Apple Card credit limit is 20 times higher than his wife's. Things got even worse for Apple when Steve Wozniak, co-founder of Apple, also tweeted he can borrow 10 times more than his partner. Both state

Meredith Broussard

Artificial Unintelligence

HOW COMPUTERS MISUNDERSTAND THE WORLD

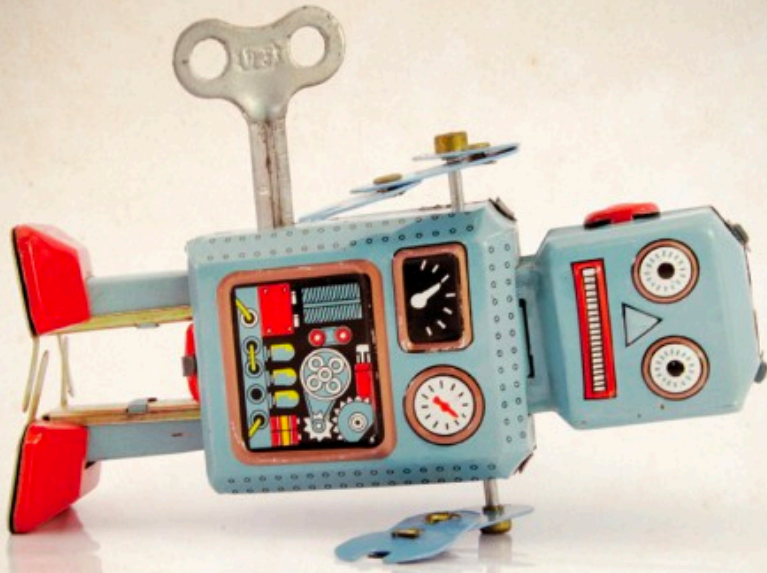

Transparency
Explainable AI
Bias checks
Value alignment



WEAPONS OF MATH DESTRUCTION



HOW BIG DATA INCREASES INEQUALITY
AND THREATENS DEMOCRACY

CATHY O'NEIL

'Fascinating and deeply disturbing'
YUVAL NOAH HARARI, GUARDIAN BOOKS OF THE YEAR

Ence gful 1m2



H. COEL. EXCUD. CUM PRIVILEGIO

DEBENT	IGNARI	RES	FERRE	ET	POST	OPERARI	QUATVOR	INSERTA	NATURIS	IN	NUBE	REFERTA
IVS	LAPIDIS	CARI	VILIS	SED	DENIQ3	RARI	NVLLA	MINERALIS	RES	EST	VBI	PRINCIPALIS
VNICA	RES	CERTA	VILIS	SED	VBIQ3	REPERTA	SED	TALIS	QUALIS	REPERITVR	VBIQ3	LOCALIS.

Act II: Creative AI & Subjective Data Sets



Universiteit
Leiden
The Netherlands

Discover the world at Leiden University

Zhirui Hu, Machine Learning Bias Game (2019). Runaway feedback loops in a predictive policing game

Week 6, crime rate



Crime you have caught: 5 Crime AI has caught: 9 Overall accuracy: 55.4%

Bursting the Bubble Example Project: Is This Clickbait?

- Clickbait classifier
- Sources: Joop, NRC, nu.nl, NOS
- First selection of 600 articles out of 300k
- Problem: how to collect labels for training data?
- Solution: Tinder based labeling game
- Credits: Mark Vonk, Robin Treur, Roel Voordendag, Friso Raad, Hogeschool Rotterdam

The image shows a screenshot of the NU.nl news website. The main headline is "Wat Rutte nu gedaan heeft geloof je niet" with a "92% clickbait" label. Below the headline is a list of articles with their respective clickbait percentages: 0%, 61%, 92%, 10%, 22%, 0%, 0%, 58%, and 2%. On the right side, there is a "Net binnen" section with a list of news items and a "Meest gelezen" section with a list of popular articles. Overlaid on the right side is a "Vind je dit clickbait?" interface with a question mark icon and a text box that says "Wat deze app gaat bewijzen geloof je nooit! Swipe nu verder!".

The image displays an abstract digital artwork. It features a dark, almost black background. Overlaid on this are several large, overlapping, semi-transparent shapes in shades of light blue and pale yellow. These shapes have a grainy, textured appearance, similar to a halftone or dithered pattern. The overall effect is ethereal and layered, with the colors blending into each other and the background. The shapes are irregular and organic, suggesting a sense of movement and depth.

Jules Verdijk (2015). *Evolving Affective Abstract Art through Measures Learned from a Corpus of Human-Made Art.*
Try it out at <http://julesver.com/examples/gen/>

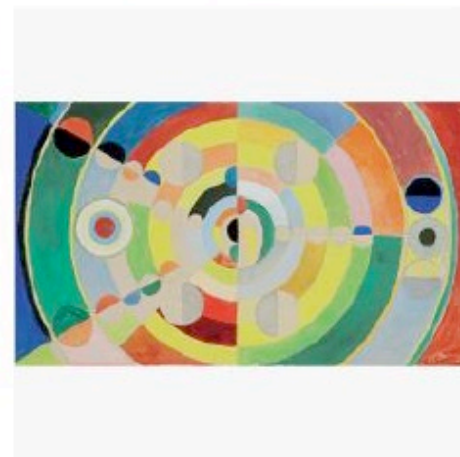
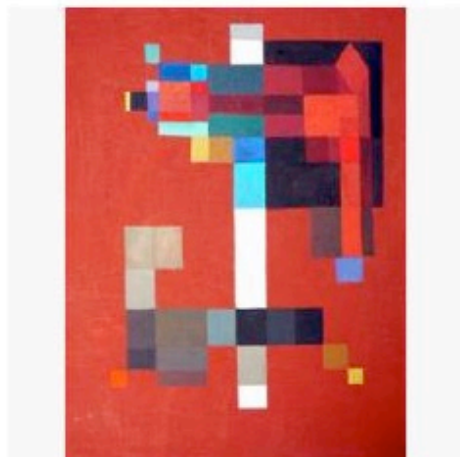
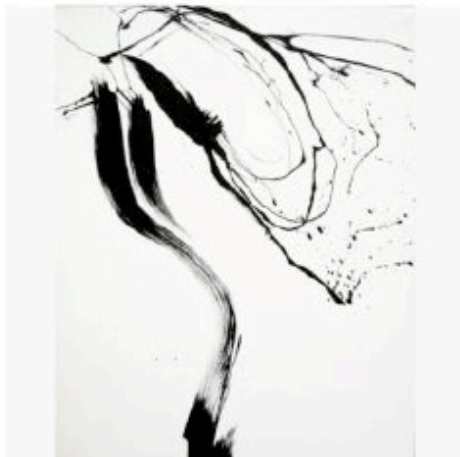
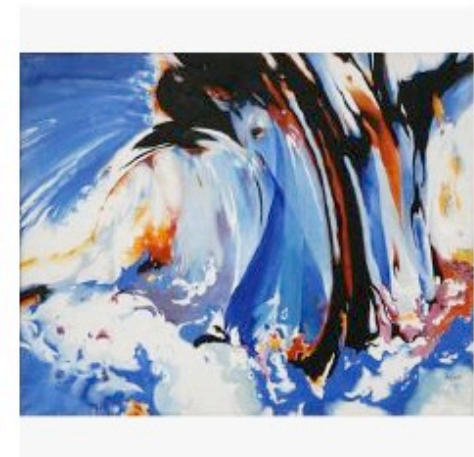
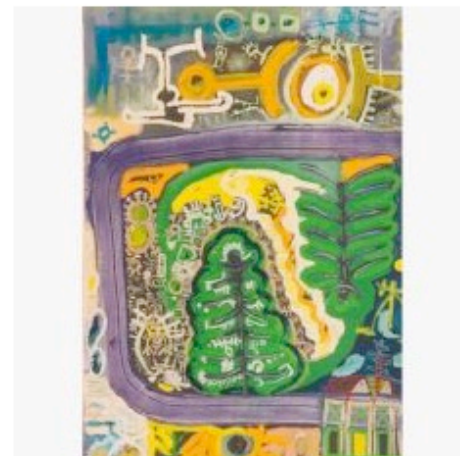
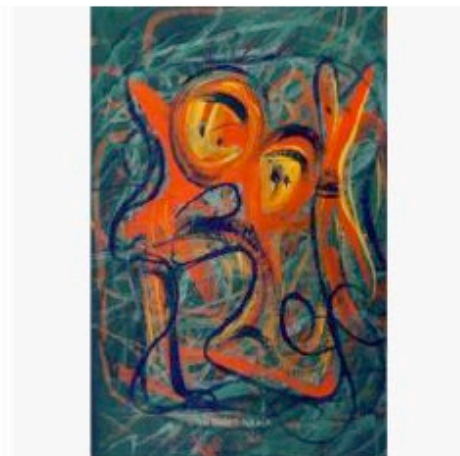
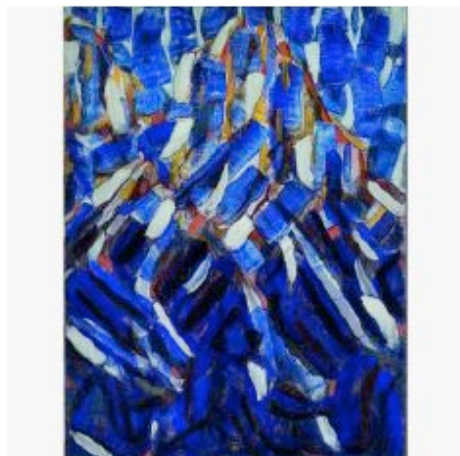
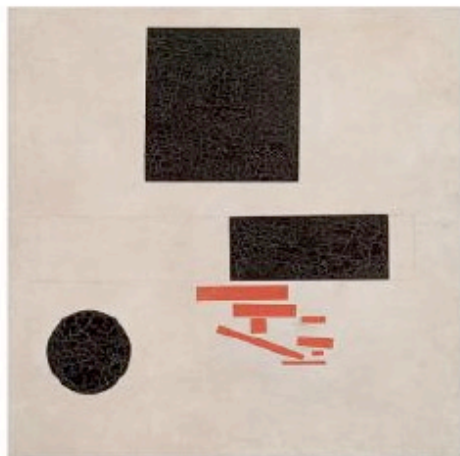
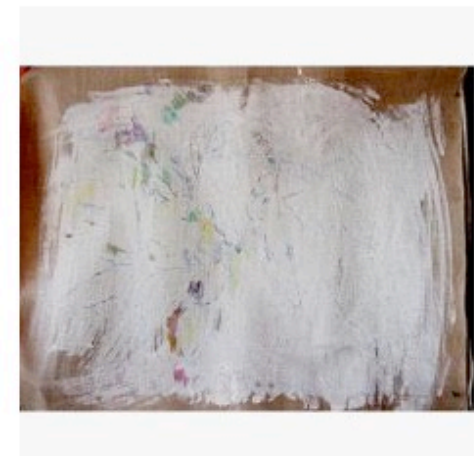

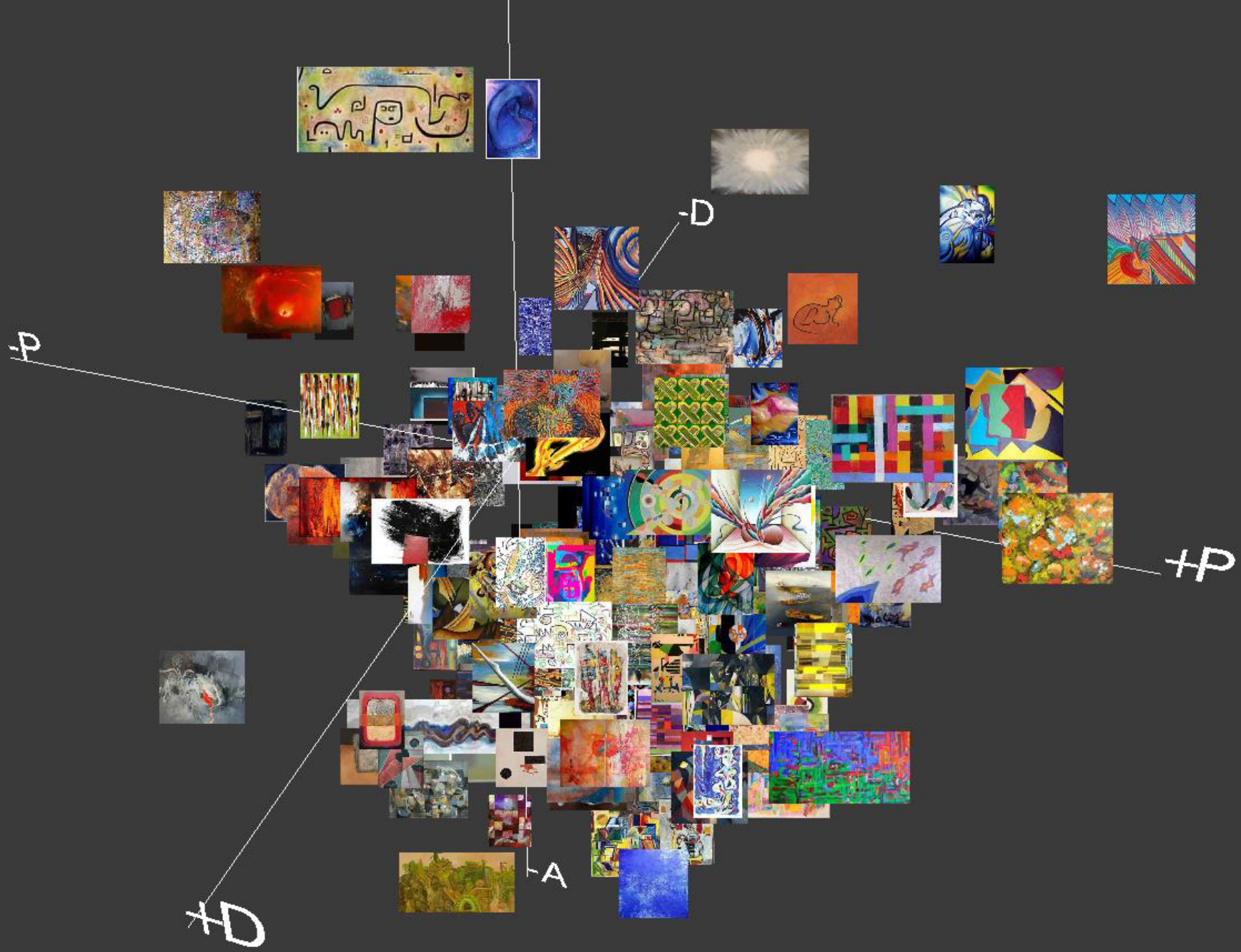

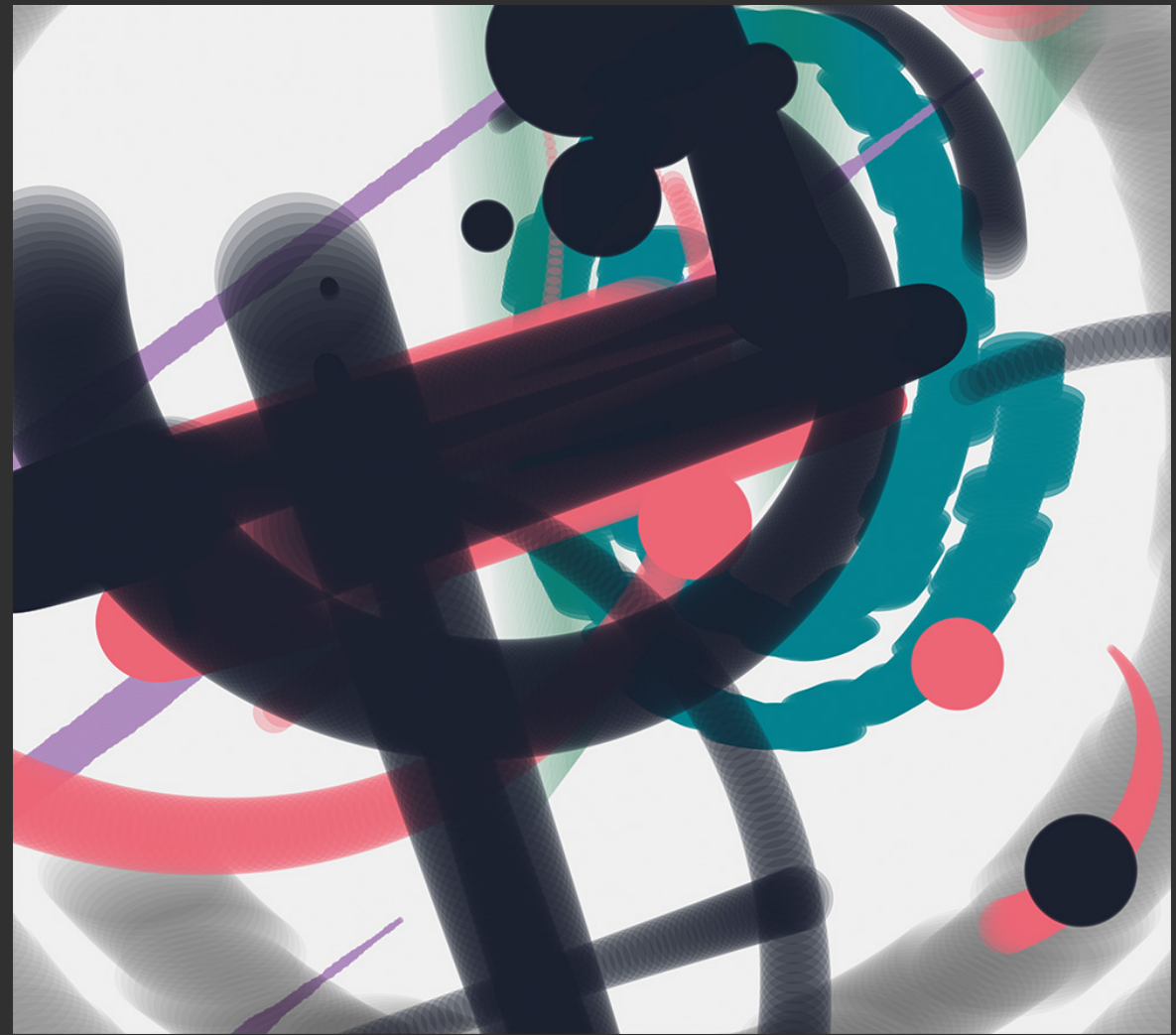
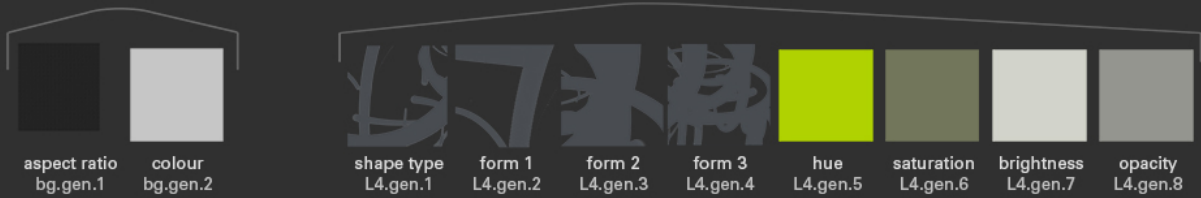
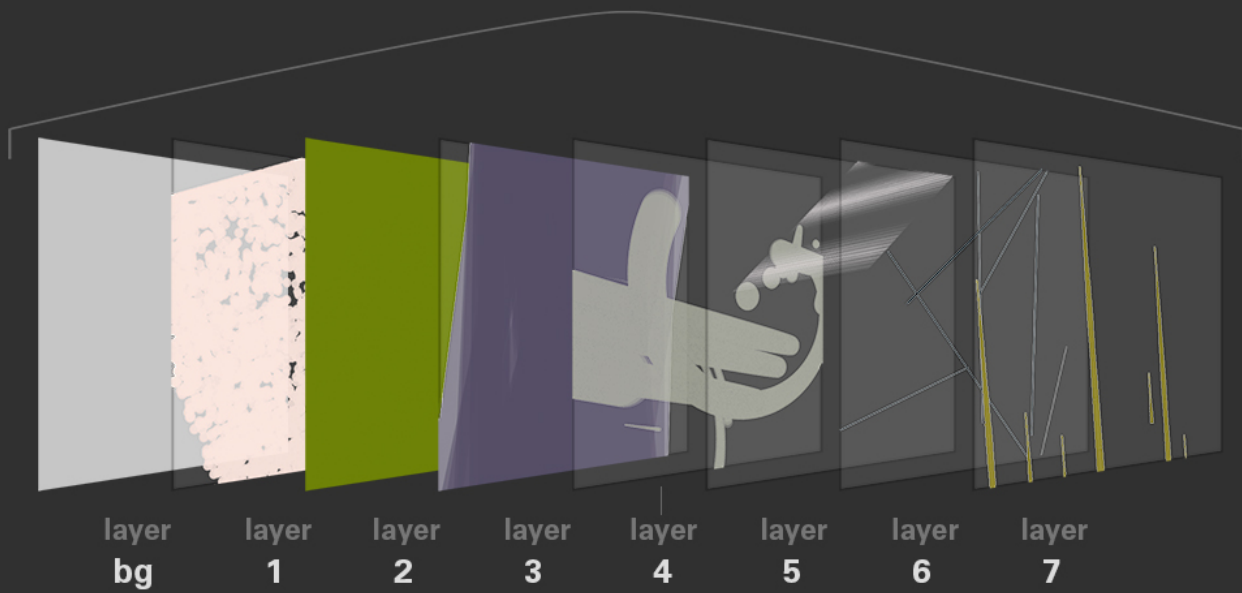

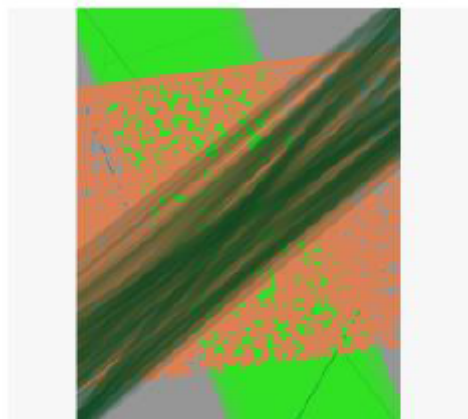
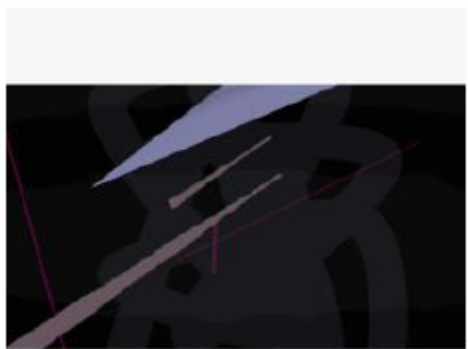
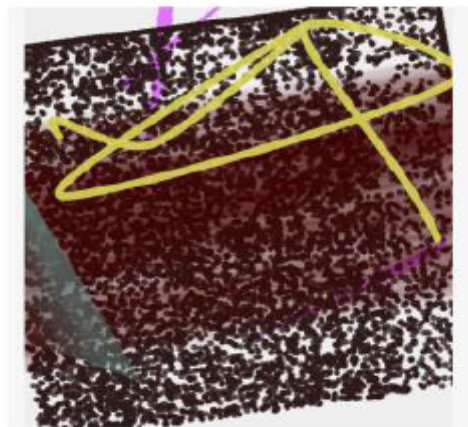
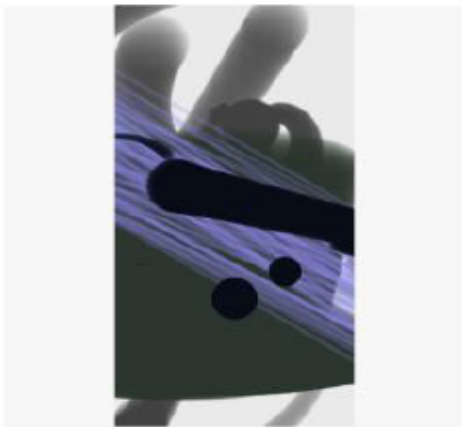
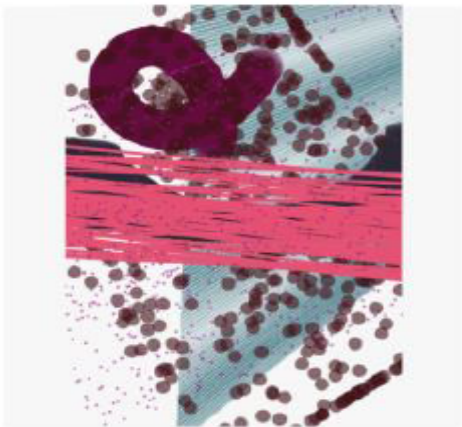
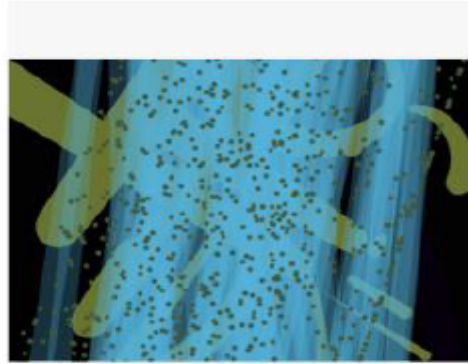
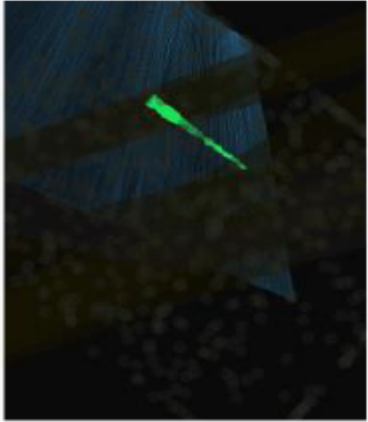
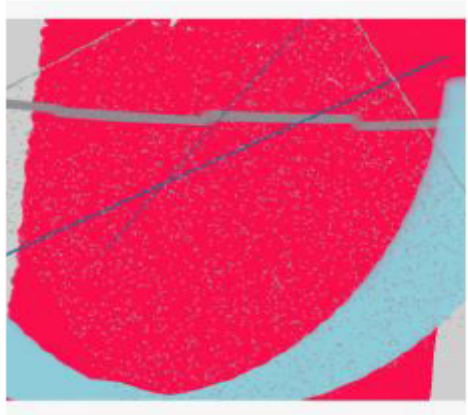

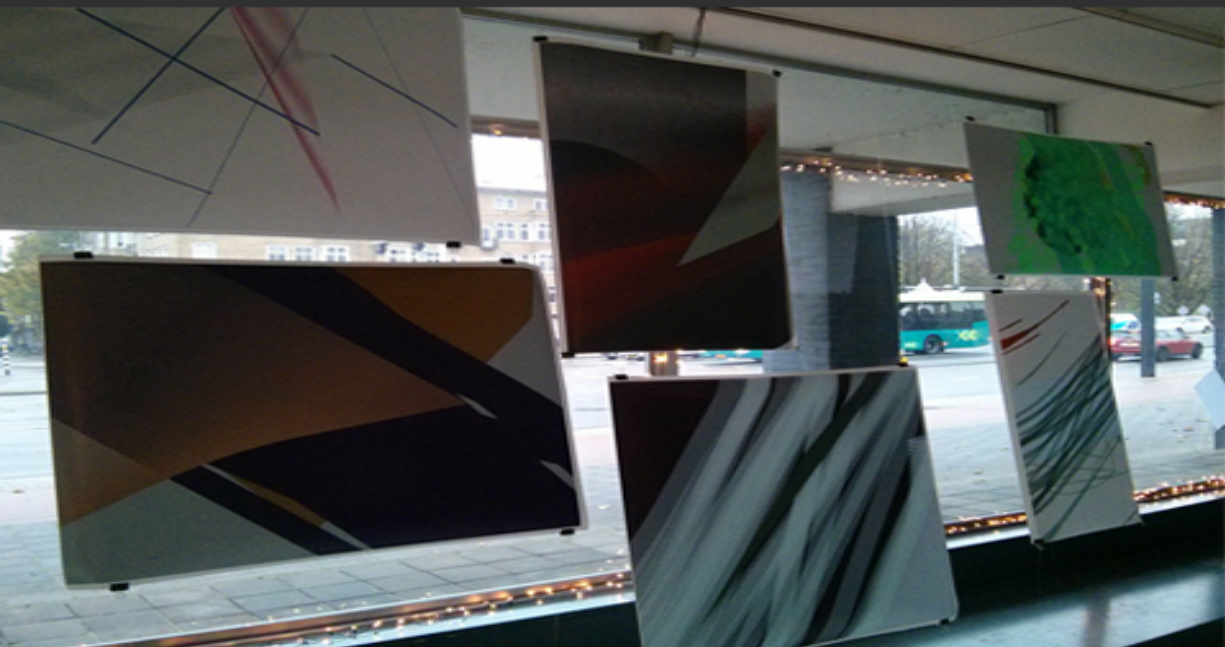

Sam Verkoelen (2015). Exploring Dimensionality Reduction on Semi-structured Photos – A Closer Look at Exactitudes.

- Exactitudes is a photo series by Ari Versluis en Ellie Uyttenbroek

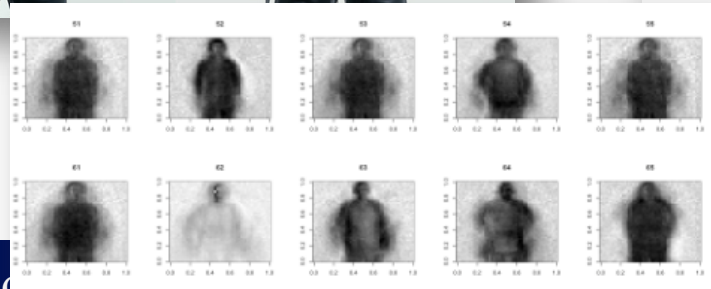
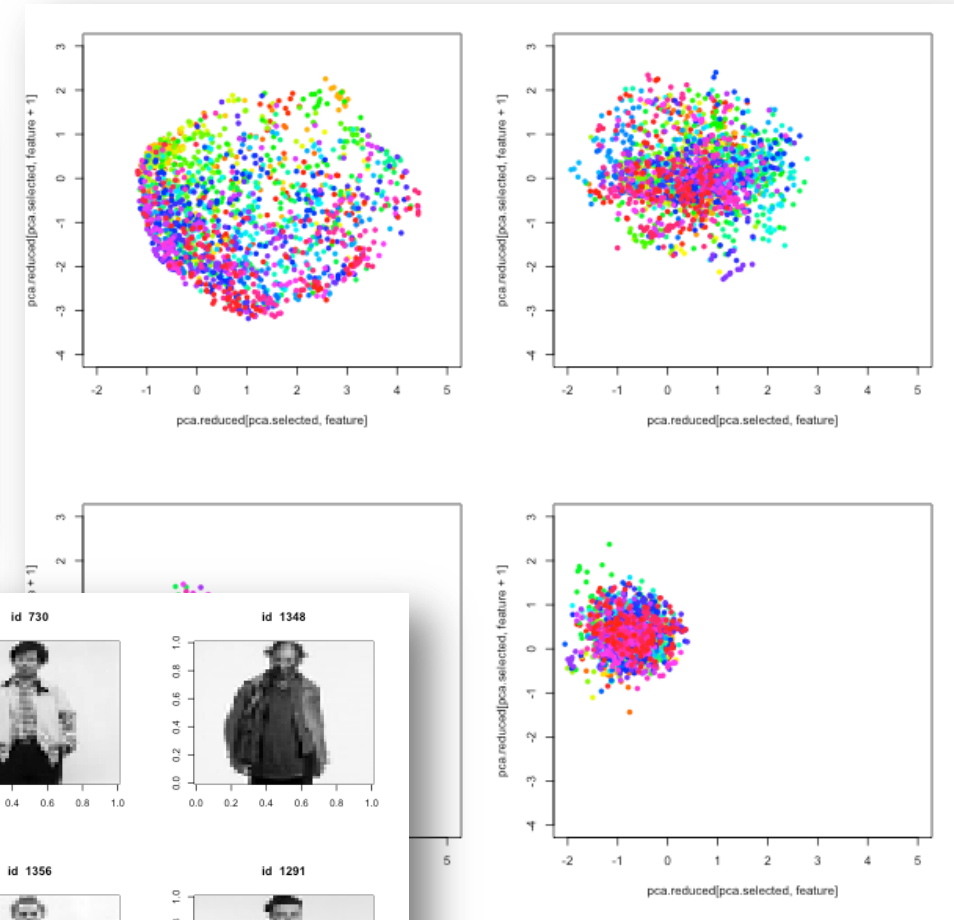

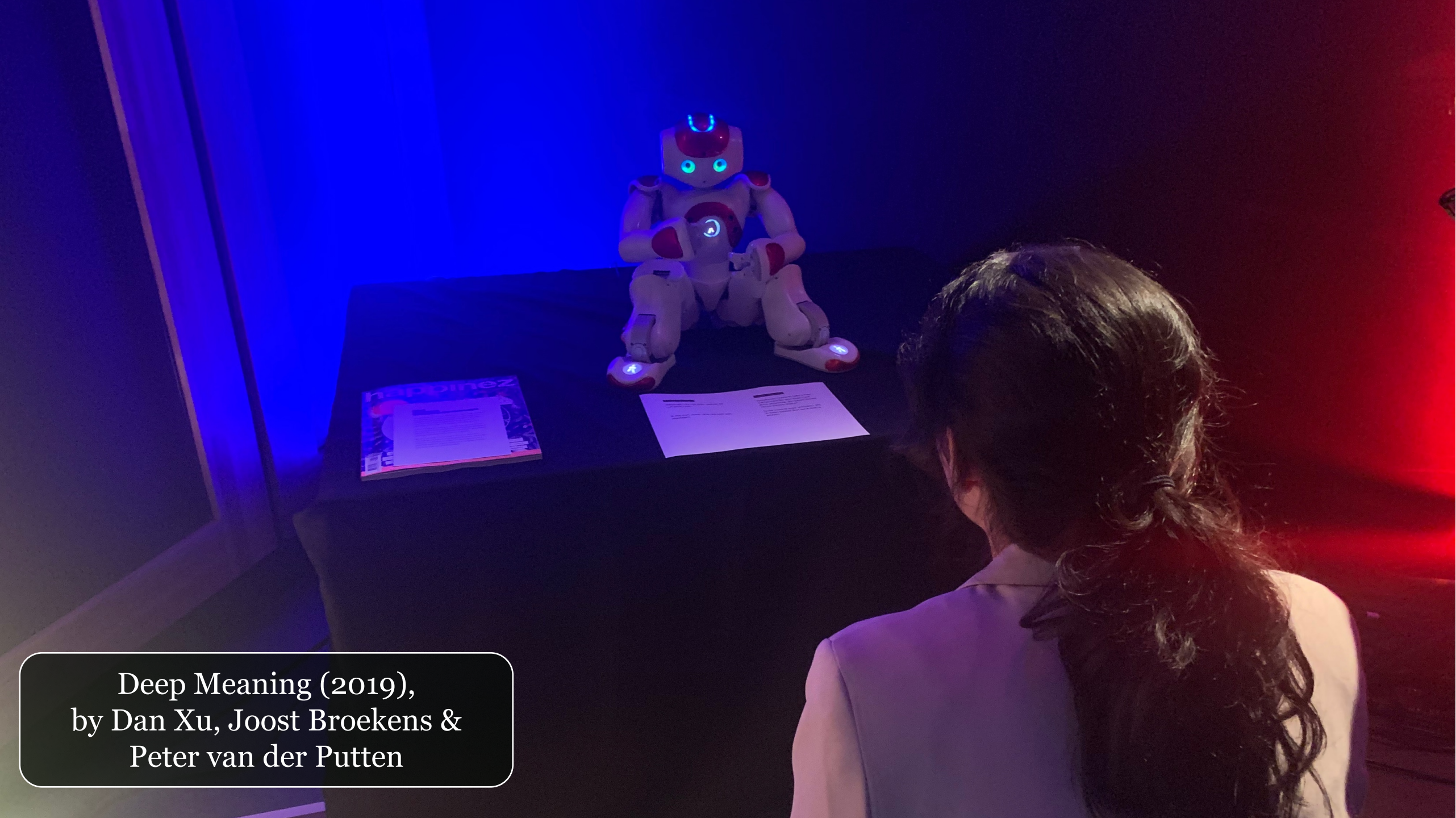

Deep Meaning (2019),
by Dan Xu, Joost Broekens &
Peter van der Putten



DEEP MEANING

*“In this hidden sense
of consciousness
has to be rebellion”*



DEEP MEANING

“Deep meaninglessness, so that the personality does not warrant what you want to do this with the outer approach to passivity.”



Brave New World is not the process. Only those who still deal with this conflict is unable to destroy the problem of the world and the limitless self-responsibility and the more you fear the consciousness of life, which is more compulsive. The ego must come from the personality that you may not be spontaneous. The superimposed conscience is an expression of the spirit world. When you feel guilty about it, you will not be free to be able to stand from the spiritual self. If I may experience the consciousness of the personality of the self to the degree that you will also be able to stress the ego faculties which can be sure that the ego is present. It is so different from the many people who can be fully aware of what they are. The difference between the feelings is the denial of the personality. If you see that the feeling is self-perpetuating on the other. The first and the medium will be to discover what you put it into a human being. The more you are not always a child, and you will see the world and the self and the experience of them from which you can never be distorted and therefore in the wrong way and the only way to guide you to give up the one who is a process of life and the first step. The desire and in the end the inner problems are all that happens to be a result of your inner faculties and destructive attitudes and interests which are supposed to be the awareness of the lower self.

artificial *intelligence*

artificial *emotions*

artificial *creativity*

artificial *helplessness*

artificial *religiousness*

artificial *futures*

artificial x

PETER VAN DER PUTTEN

DATA MINER
AND CREATIVE RESEARCHER

DIVE IN



Thank you!

Peter van der Putten

p.w.h.van.der.putten@liacs.leidenuniv.nl

<http://liacs.leidenuniv.nl/~puttenpwhvander/>

<https://www.linkedin.com/in/petervanderputten/>



**Universiteit
Leiden**
The Netherlands